

# T ECHNICAL INFORMATION

**Makita**

PRODUCT

P 1 / 15

**Models No.** ▶ JR3070CT

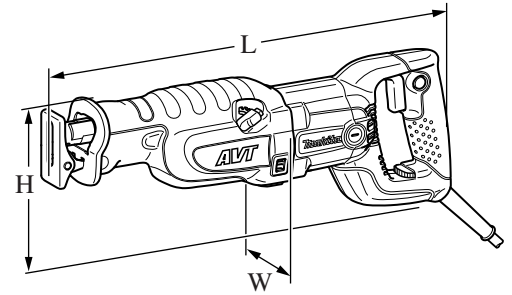
**Description** ▶ Recipro Saw

## CONCEPT AND MAIN APPLICATIONS

Model JR3070CT has been developed as the highest specification model in Makita Recipro Saws.

Features electronic control and orbital mechanism for extra-high cutting efficiency while ensuring low vibration performance with our innovative AVT (Anti-Vibration Technology).

Additionally, provides more control and comfort with toolless blade change, toolless shoe adjustment and rubberized soft grip.



Dimensions: mm (")	
Length (L)	485 (19-1/8)
Width (W)	99 (3-7/8)
Height (H)	181 (7-1/8)

## ► Specification

Voltage (V)	Current (A)	Cycle (Hz)	Continuous Rating (W)		Max. Output(W)
			Input	Output	
110	14.5	50/60	1,510	650	1,600
120	15	50/60	1,700	950	1,600
220	7.2	50/60	1,510	650	1,600
230	6.9	50/60	1,510	650	1,600
240	6.6	50/60	1,510	650	1,600

Stroke per minute: min-1	0 - 2,800	
Length of Stroke: mm (")	32 (1-1/4)	
Capacity	*Wood: mm (")	255 (10)
	Pipe: dia. mm (")	130 (5-1/8)
Variable speed control	Yes	
Net weight: kg (lbs)	4.4 (9.7)	
Power supply cord: m (ft)	Europe: 4.0 (13.1) Australia: 2.0 (6.6) Other countries: 2.5 (8.2)	

\*when cutting with the supplied 300mm (11-3/4") length reciprocating saw blade.

## ► Standard equipment

### North America:

Recipro saw blade (for Steel)  
Recipro saw blade (for Composite)  
Steel carrying case

### All countries other than North America:

Recipro saw blades No.21 (for Steel)  
Recipro saw blades No.22 (for Steel)  
Recipro saw blade No.23 (for Wood and Plywood)  
Plastic carrying case

**Note:** The standard equipment for the tool shown above may differ by country.

## ► Optional accessories

Recipro saw blades No.21, 22, 24 (for Steel)  
Recipro saw blade No.23, 23B (for Wood and Plywood)

## ► Repair

**CAUTION: Remove the saw blade from the machine for safety before repair/ maintenance !**

### [1] NECESSARY REPAIRING TOOLS

Code No.	Description	Use for
1R291	Retaining Ring S and R Pliers	Installing/removing Retaining rings S-18 and S-12
----	Recipro saw blade	Inserting push plate into blade clamp section of slider
1R327	Torx screwdriver T25H120	Installing/removing Torx countersunk head screw
1R314	Torx bit VT-25	Installing/removing Torx countersunk head screw
1R269	Bearing extractor (small)	Removing Ball bearing 6001DDW
1R280	Round bar for arbor 6-50	Removing pin 7
1R247	Round bar for arbor 20-100	Removing Ball bearing 6003LLB
1R245	Round bar for arbor 16-100	Removing torque limiter complete
1R041	Vise plate	Protecting crank cam complete, when fasten it with vise
1R268	Spring pin extractor	Removing shift button
1R223	Torque wrench shaft 20-90N.m	Tightening torque limiter complete
1R254	Torque wrench shaft 2-6N.m	Tightening torx socket head screw M5x14

### [2] LUBRICATION AND ADHESIVE APPLICATION

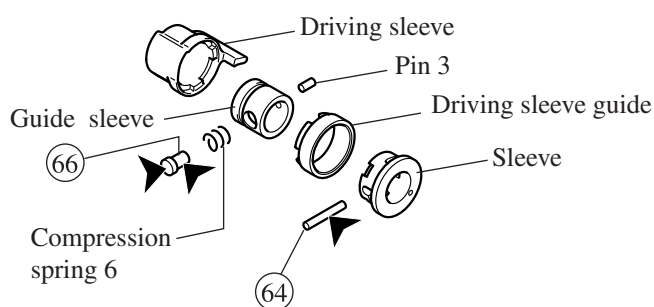
#### [2] -1. LUBRICATION

##### Blade Clamp Section

Apply Makita grease FA No.2 to the following portions designated with the black triangle to protect parts and product from unusual abrasion.

Item No.	Description	Portion to lubricate
64	Pin 3	Surface which contacts Slider
66	Shoulder pin 5	Head which contacts Driving sleeve
		Surface which contacts Guide sleeve

**Fig. 1**



# ▶ Repair

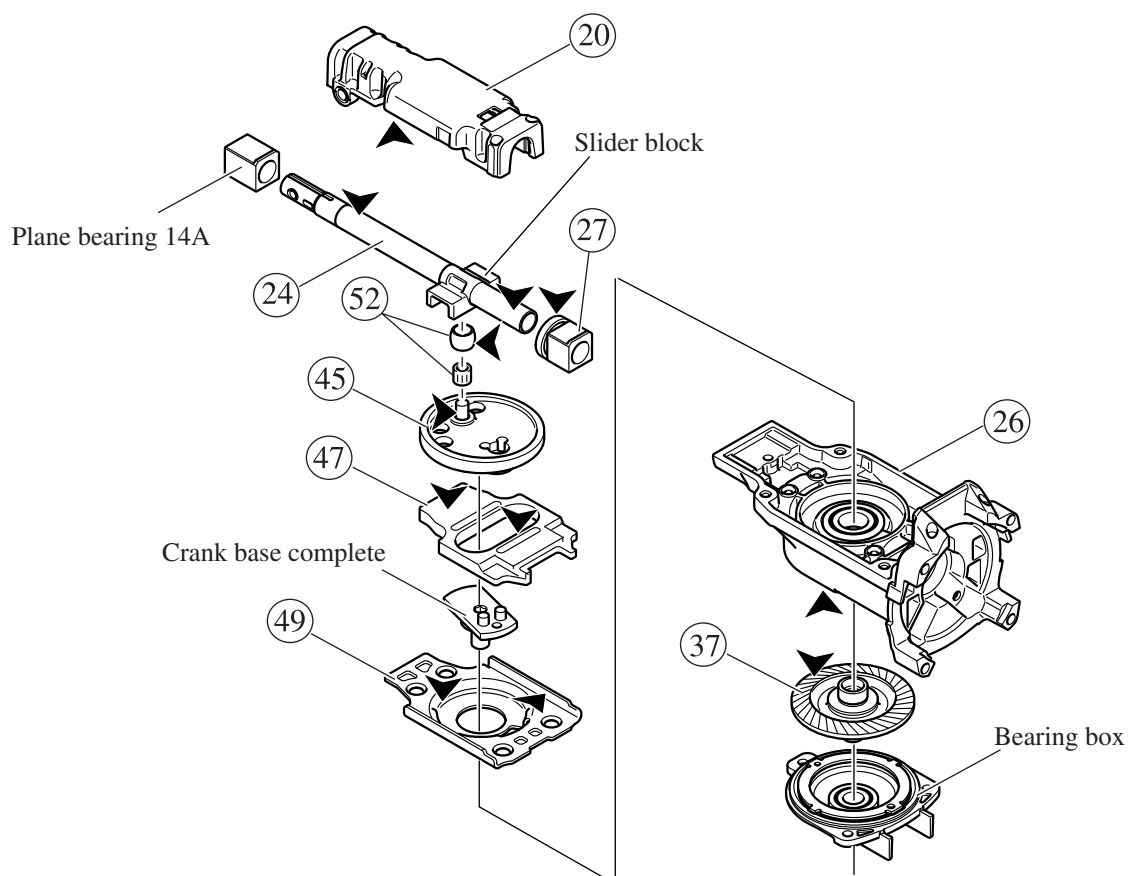
## [2] -1. LUBRICATION (cont.)

### Gear and Reciprocation Mechanisms

Apply Makita grease FA No.2 to the following portions designated with the black triangle to protect parts and product from unusual abrasion.

Item No.	Description	Portion to lubricate
20	Slider support	Inside surface where Slider reciprocates. Apply approx. 12g.
24	Slider	Whole surface
26	Gear housing	Gear room where (37) Torque limiter rotates. Apply approx. 15g.
27	Bearing complete	Circumference of Ball bearing portion which contacts (45) Crank cam complete
37	Torque limiter	Teeth portion
45	Crank cam complete	Boss on which (52) Needle bearing 710 is installed
47	Counterweight	Surface that contacts Crank cam complete
49	Bearing retainer B	Surface which contacts (48) Ring 21B
52	Needle bearing 710	Outer surface of the outer ring which contacts the slider block of (24) Slider

**Fig. 2**



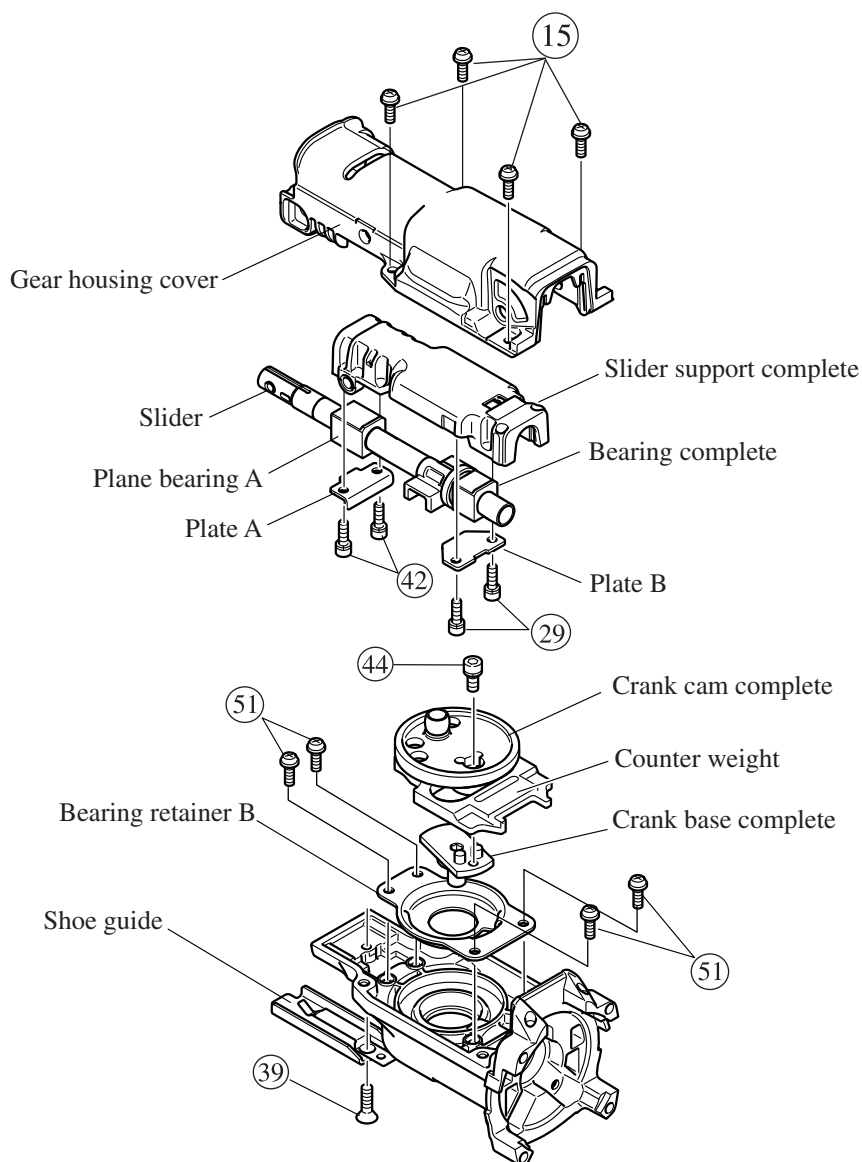
► **Repair**

**[2] -2. ADHESIVE APPLICATION**

Apply adhesive to the following screws to prevent them from loosening.

Item No.	Description	Apply for
(15)	Pan head screw M5x16 (4 pcs)	Securing Gear housing cover
(29) (42)	Hex socket head bolt M5x16 (4 pcs)	Tightening Plate A and B
(39)	Countersunk head screw M6x16 (1 pc)	Securing Shoe guide
(44)	Hex socket head bolt M6x14 (1 pc)	Securing Crank cam complete to Crank base complete
(51)	Pan head screw M5x16 (4 pcs)	Securing Bearing retainer B

**Fig. 3**



## ► Repair

### [3] DISASSEMBLY/ASSEMBLY

#### [3] -1. Disassembling/ Assembling Blade Clamp Section

##### DISASSEMBLING

- 1) Remove shoe. If the blade clamp section is positioned inside gear housing, pull it out of gear housing. (Fig. 4)
- 2) After removing protector, remove retaining ring S-18 with Retaining Ring S and R Pliers (No.1R291).  
Then remove the following parts:  
Driving sleeve, Shoulder pin 5, Compression spring 6,  
Pin 3 (of 6mm length), Guide sleeve, Driving sleeve guide  
Now sleeve appears. (Fig. 5)

Fig. 4

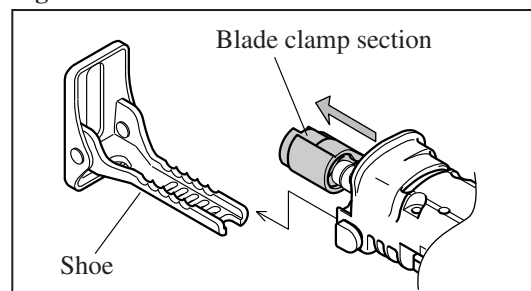
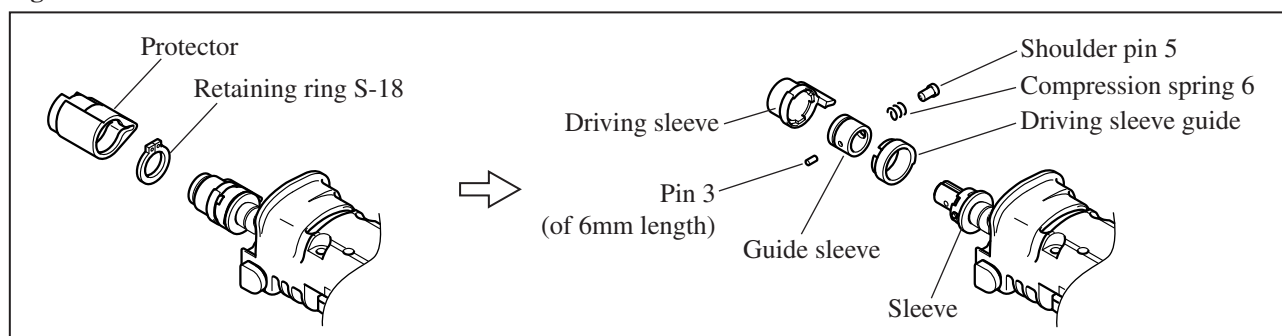
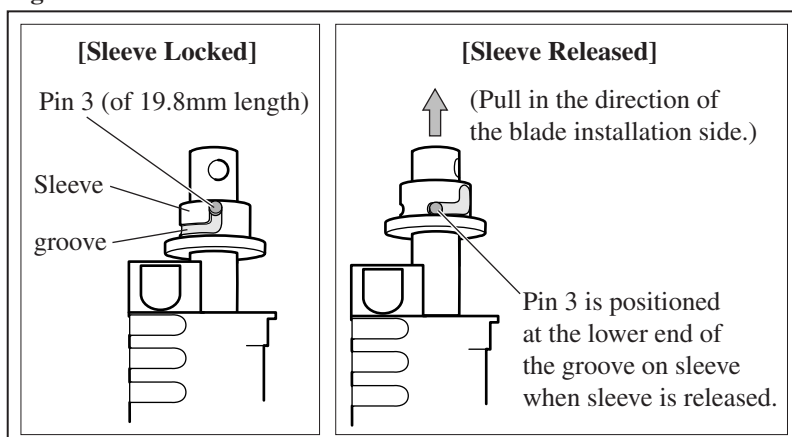


Fig. 5



- 3) Because sleeve is locked, release it by pulling in the direction of the blade installation side. (Fig. 6)

Fig. 6



- 4) While putting your finger on the top of slider to close the slit of slider, remove pin 3 (of 19.8mm length) by pushing with a thin bar. (Fig. 7)

**Note:** Be sure to put your finger on the top of slider or push plate will pop out from the slit of slider.

- 5) Remove sleeve and torsion spring 17 from slider, then take push plate and compression spring 2 out of the slit of slider. (Fig. 8)

Fig. 7

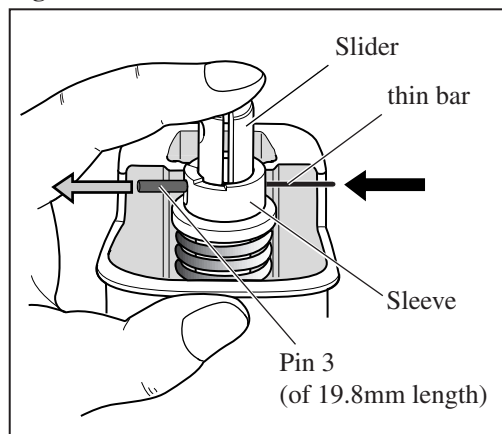
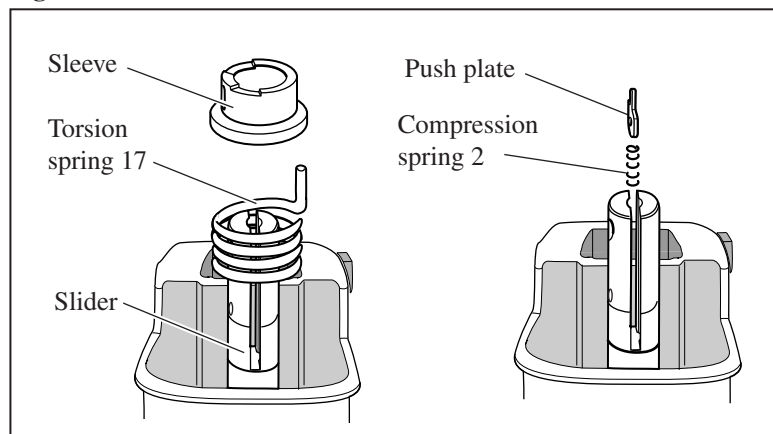


Fig. 8



## ► Repair

### [3] -1. Disassembling/ Assembling Blade Clamp Section (cont.)

#### ASSEMBLING

1) Assemble torsion spring 17 to slider as illustrated in **Fig. 9**.

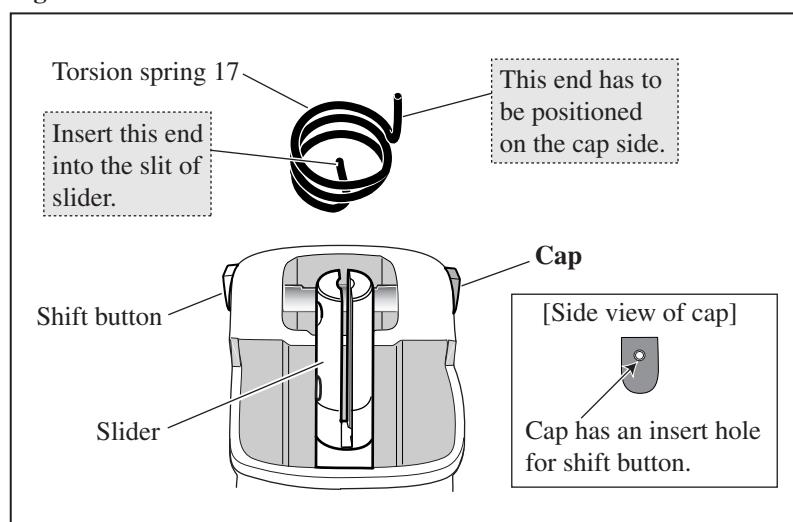
**Important:** Be sure that torsion spring 17 is not reversible when assemble to slider.

Follow the instruction described in **Fig. 9**.

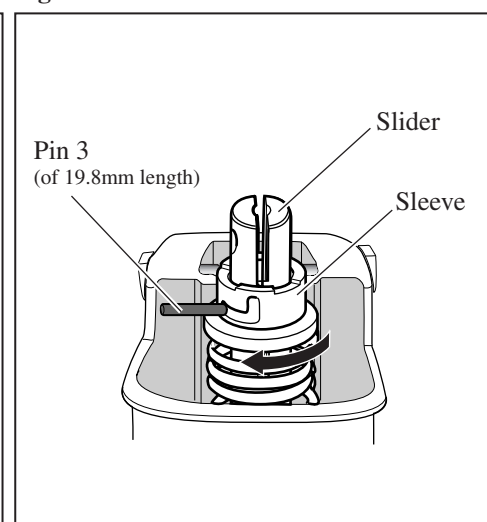
2) Insert compression spring 2 into the slit of slider.

3) Install sleeve on slider and lock pin 3 temporarily by turning sleeve clockwise. (**Fig. 10**)

**Fig. 9**



**Fig. 10**



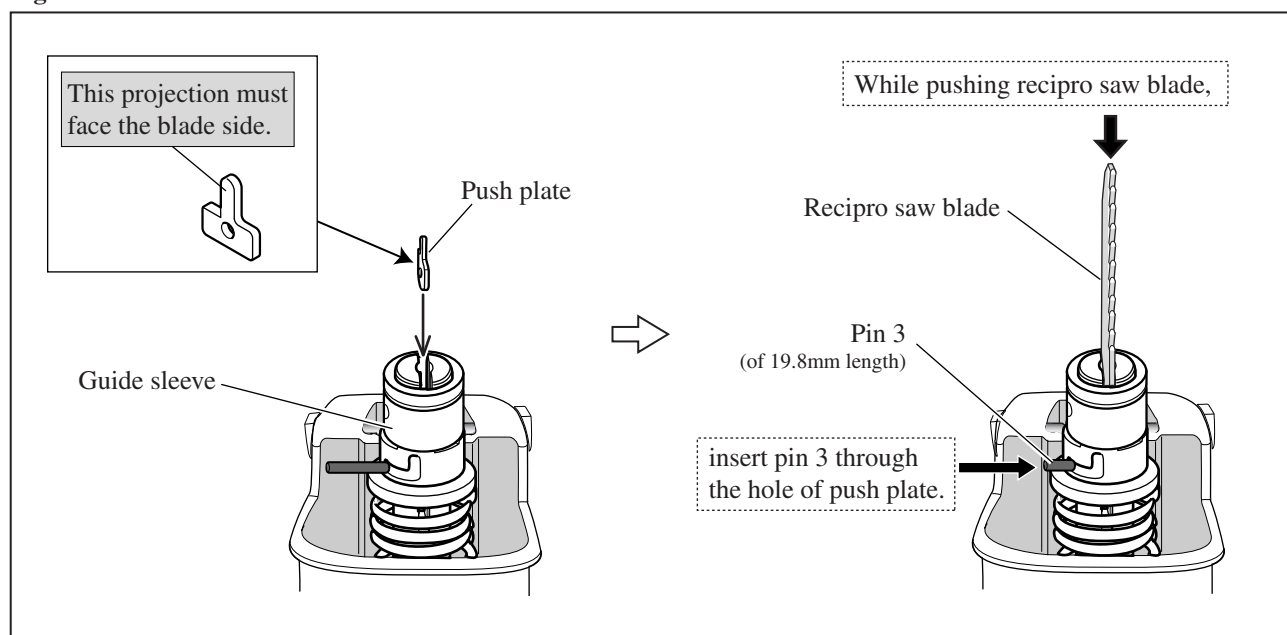
4) Mount guide sleeve temporarily, and put push plate into the slit of slider as illustrated to left in **Fig. 11**.

**Important:** Be sure that push plate is not reversible when installed.

While pushing push plate straight into slider with reciprocating saw blade, insert pin 3 (of 19.8mm length) through the hole of push plate as illustrated to right in **Fig. 11**. And then remove guide sleeve.

**Note:** Guide sleeve is used as a jig, not assembled to slider yet in this step.

**Fig. 11**



## ► Repair

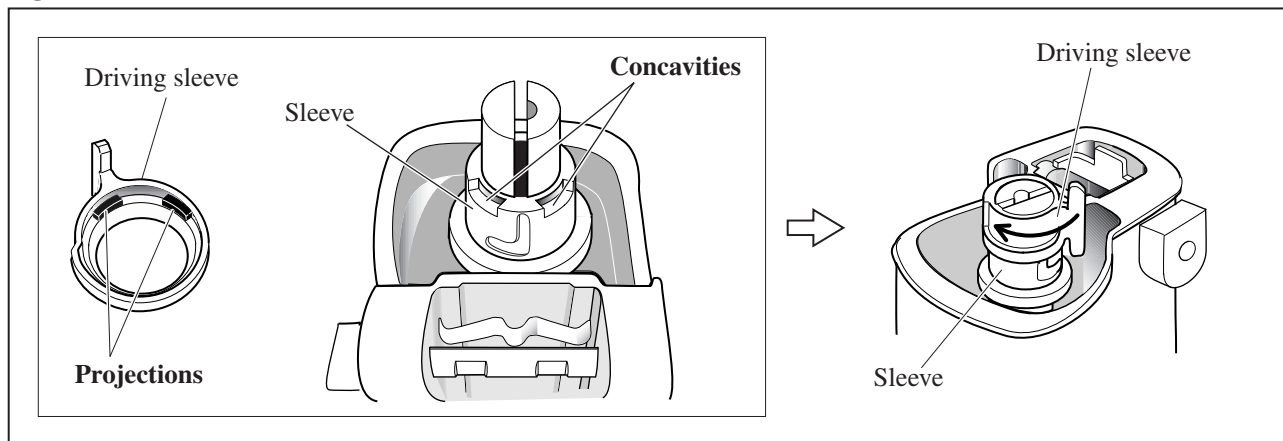
### [3] -1. Disassembling/ Assembling Blade Clamp Section (cont.)

5) While fitting the two projections of driving sleeve in the concavities of sleeve, push driving sleeve into gear housing. At this time, turn driving sleeve clockwise so that the protruding portion of driving sleeve cannot be interfered by gear housing. After driving sleeve is pushed into gear housing to the full, turn driving sleeve clockwise to lock pin 3 in place. (Fig. 12)

**Note:** Driving sleeve is used as a jig to lock pin 3 in place, not assembled to slider in this step.

6) Remove driving sleeve.

**Fig. 12**



7) Assemble the following parts to slider (Refer to Fig. 5.):

Driving sleeve guide, Guide sleeve, Pin 3 (of 6mm length), Shoulder pin 5, Compression spring 6

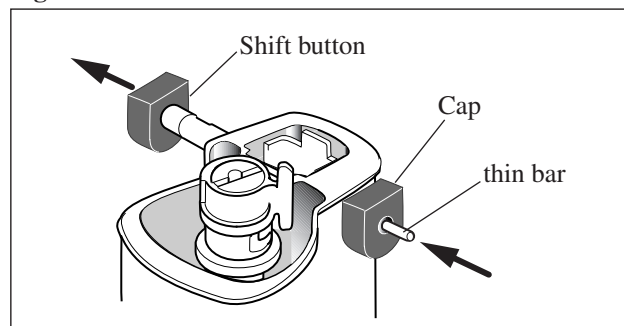
8) Put driving sleeve over guide sleeve and secure it with retaining ring S-18 using 1R291. Then cover driving sleeve with protector. (When installing driving sleeve, fit its projections in the concavities of sleeve and driving sleeve guide.)

### [3] -2. Replacing Shift Button and Cap

#### DISASSEMBLING

Shift button can be removed from gear housing cover by inserting a thin bar into the hole of cap and push the bar. (Fig. 13)

**Fig. 13**



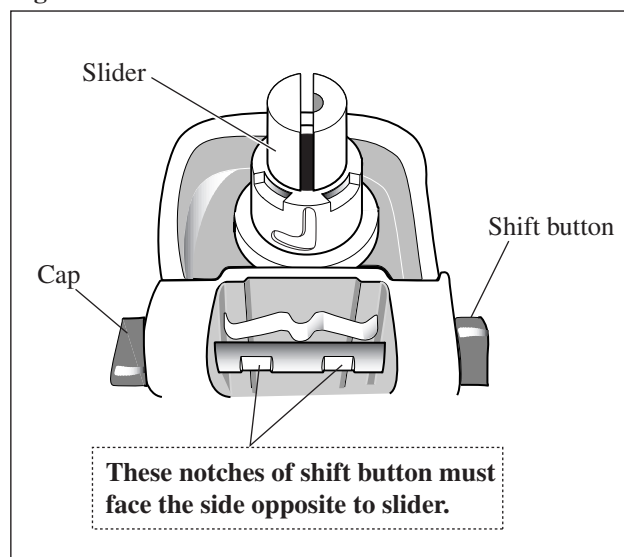
#### ASSEMBLING

- 1) Replace cap by new one because removal of shift button damages the inside surface of cap.
- 2) From shift button, remove all the plastic dust scraped off the removed cap. Insert shift button through the holes in the both sides of gear housing cover. And then press-fit shift button in the new cap by hand.

#### **Important:**

Be sure to assemble shift button to gear housing cover so that the two notches of shift button face the side opposite to slider as illustrated in Fig. 14.

**Fig. 14**



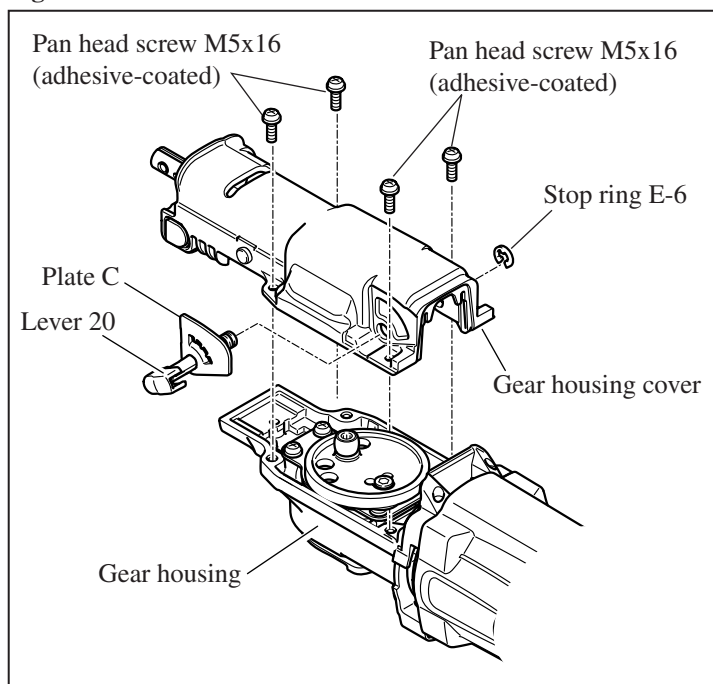
► **Repair**

**[3] -3. Disassembling/ Assembling Slider**

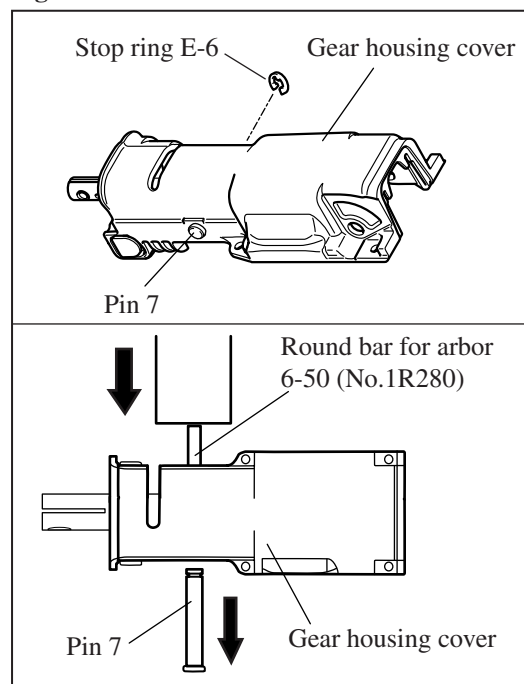
**DISASSEMBLING**

- 1) After removing shoe and insulation cover, remove the blade clamp section. (Refer to [3]-1.)
- 2) Separate gear housing cover from gear housing by removing four M5x16 pan head screws (adhesive). (**Fig. 15**)
- 3) Remove stop ring E-6, and then take off lever 20 from gear housing cover. (**Fig. 15**)
- 4) Remove another stop ring E-6 from the end of pin 7 as illustrated above in **Fig. 16**.  
Applying Round bar for arbor 6-50 (No.1R280 ) to the same end of pin 7, push it with arbor press.  
Now pin 7 can be removed from gear housing cover as illustrated below in **Fig. 16**.
- 5) Separate slider section (slider support, seal plate 14, plane bearing 14A, slider, slide plate, bearing complete, plates A and B) from gear housing cover. (**Fig. 17**)
- 6) Remove plates A and B by unscrewing four M5x16 hex socket head bolts. (**Fig. 18**)

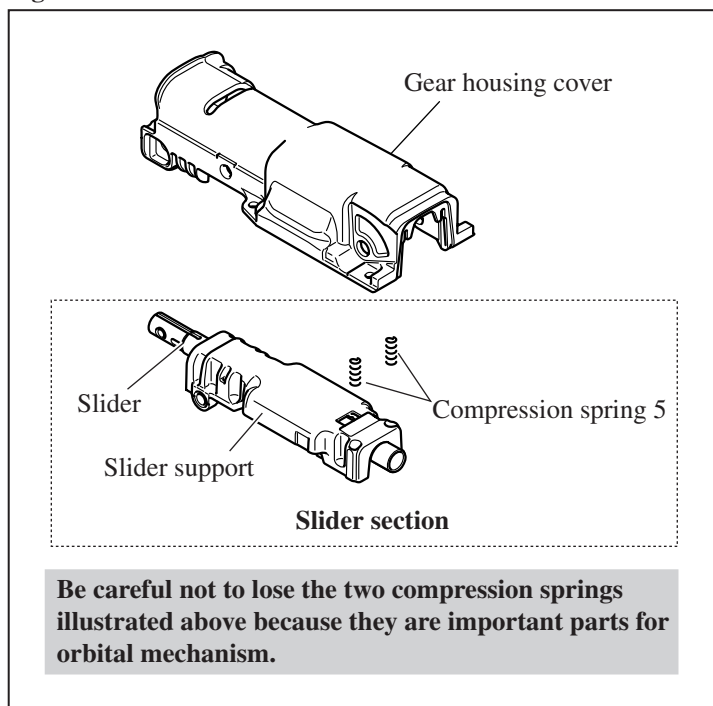
**Fig. 15**



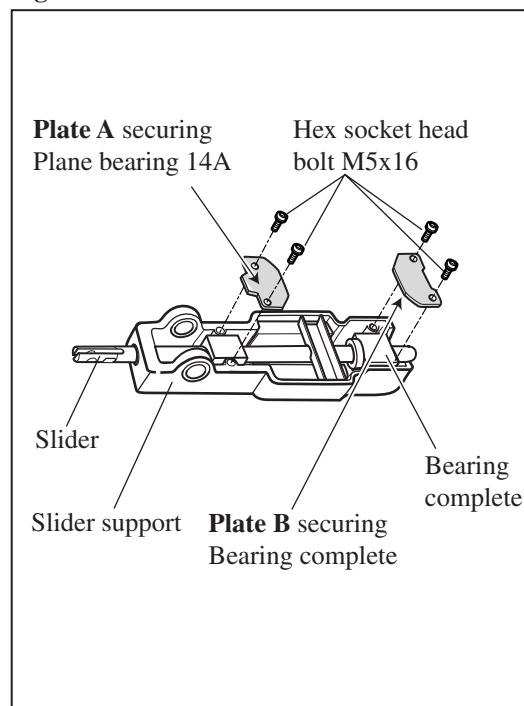
**Fig. 16**



**Fig. 17**



**Fig. 18**





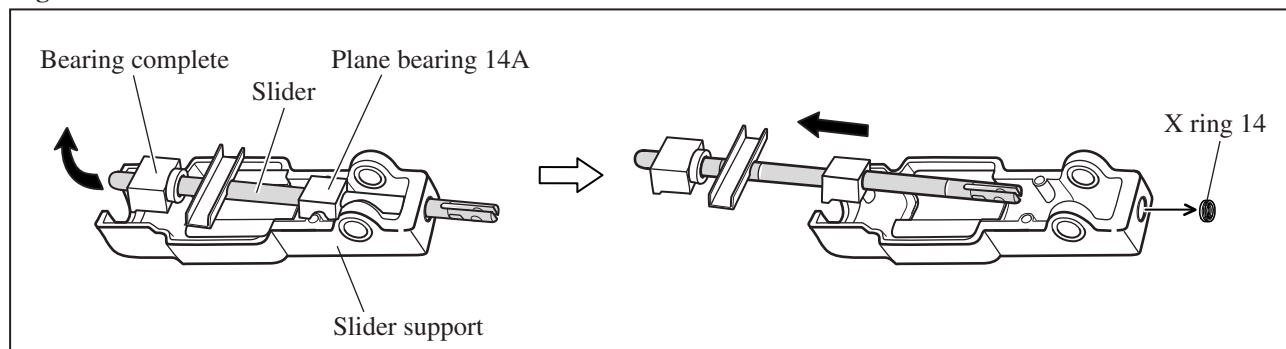
## ► Repair

### [3] -3. Disassembling/ Assembling Slider

#### DISASSEMBLING

- 7) While raising the end of bearing complete side, remove slider from slider support by pulling in the direction of the arrow. (Fig. 19)
- 8) Remove X ring 14 from slider support. (Fig. 19)

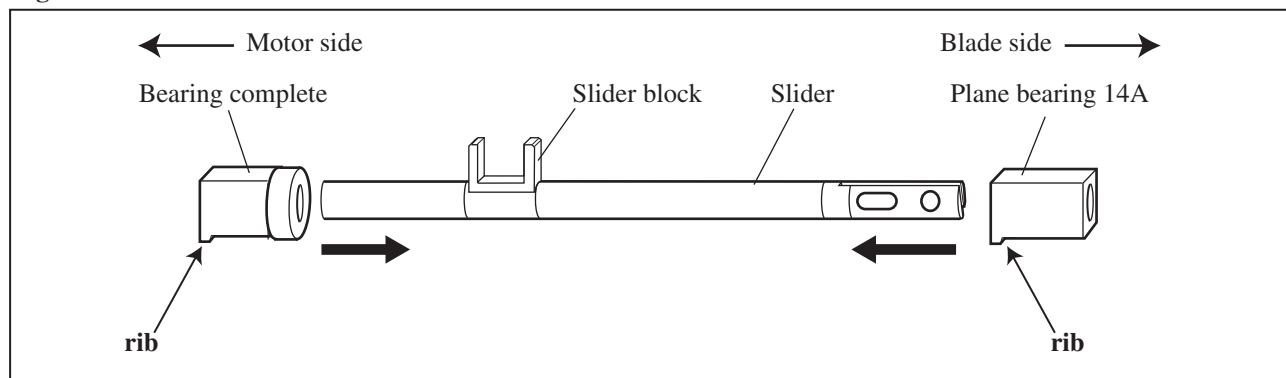
Fig. 19



#### ASSEMBLING

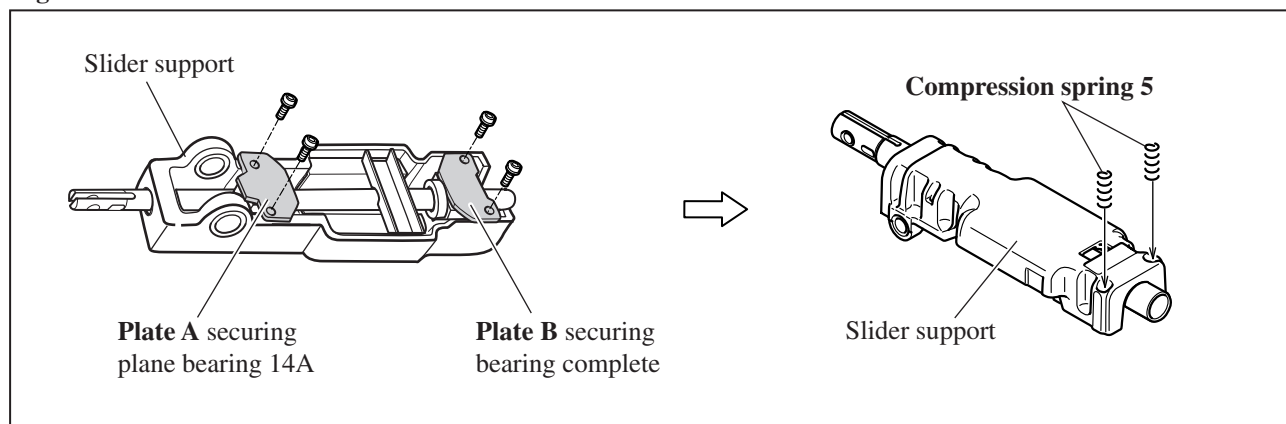
- 1) Install X ring 14 on slider support. (Refer to Fig. 19.)
  - 2) Put bearing complete on the motor side-end of slider, and plane bearing 14A on the blade side-end of slider. (Fig. 20)
- Important:** Bearing complete and plane bearing 14A are both not reversible when assembled to slider.  
Be sure to place them so that the rib on bearing complete/ plane bearing 14A faces toward the motor side.

Fig. 20



- 3) Mount slider to slider support. (Refer to Fig. 19.)
- 4) Fasten plate A and plate B to slider support as illustrated to left in Fig. 21.
- 5) Mount compression spring 5 (2 pcs) to slider support as illustrated to right in Fig. 21.

Fig. 21



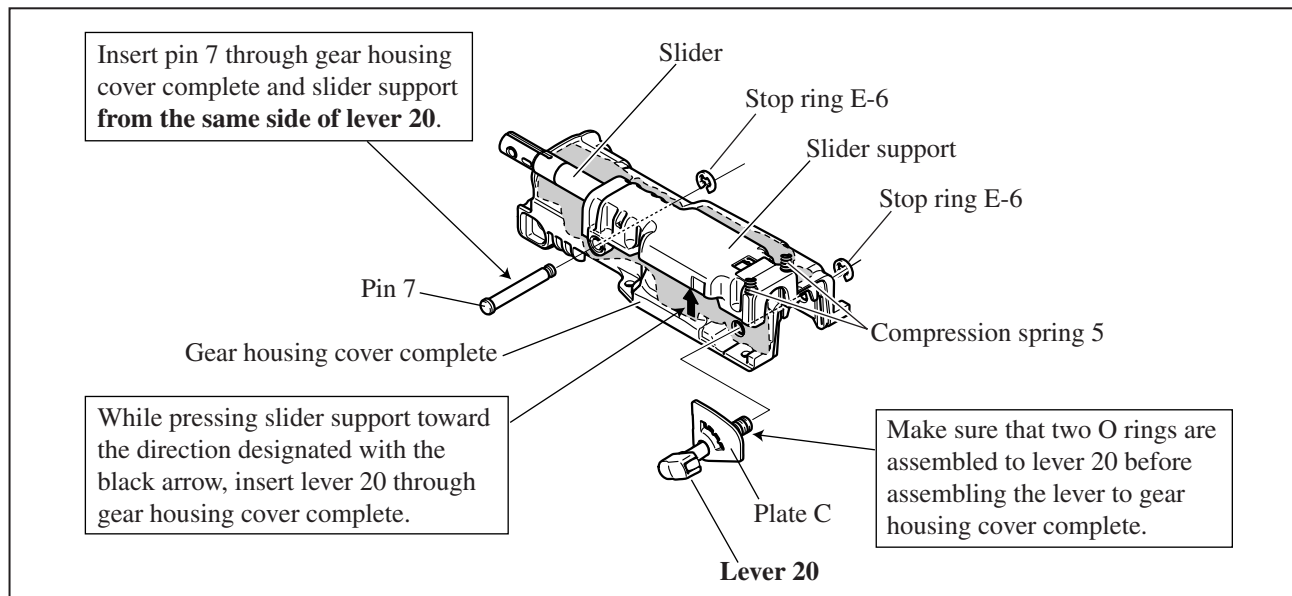
## ► Repair

### [3] -3. Disassembling/ Assembling Slider (cont.)

#### ASSEMBLING

6) Assemble slider support to gear housing cover complete as illustrated in Fig. 22.

Fig. 22



### [3] -4. Replacing Torque Limiter Complete

#### DISASSEMBLING

- 1) After removing insulation cover and shoe, separate gear housing cover complete from gear housing. (Fig. 15)  
It is not necessary to remove lever 20 and pin 7.
- 2) Remove bearing box from gear housing by unscrewing three M5x16 pan head screws (adhesive-coated), then the hexagon hole of torque limiter will be visible. (Fig. 23)
- 3) Secure crank cam complete in vise, then insert hex wrench into the hexagon hole. By turning the hex wrench counterclockwise, torque limiter can be disconnected from crank base complete of the crank section. (Fig. 24)

#### CAUTION:

Never use impact driver for turning the hexagonal hole of torque limiter or you may alter the factory-adjusted torque setting.

- 4) Separate crank cam complete and crank base complete from torque limiter.

Fig. 23

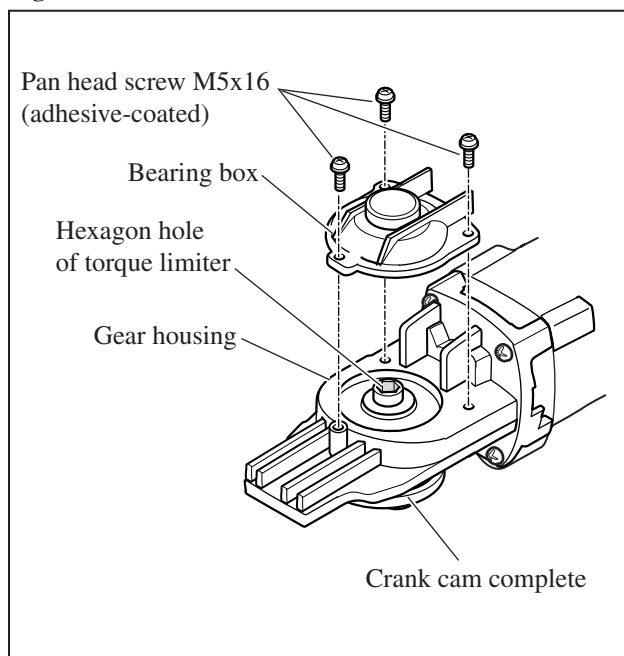
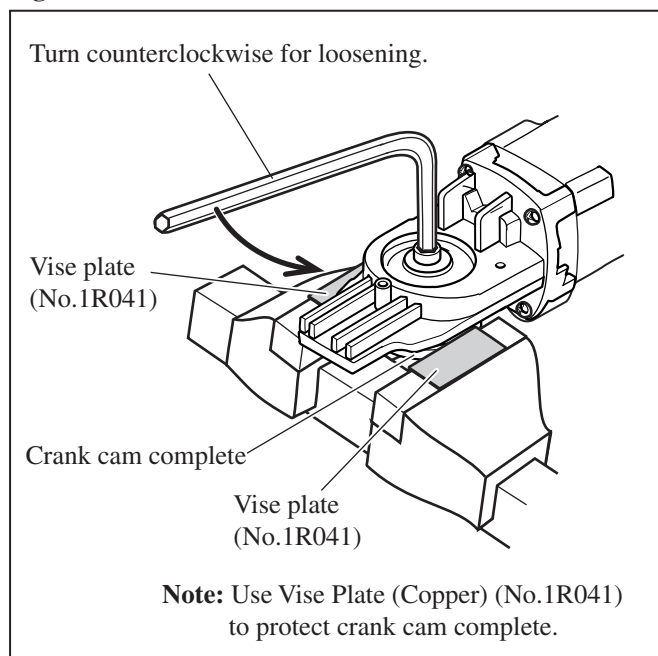


Fig. 24



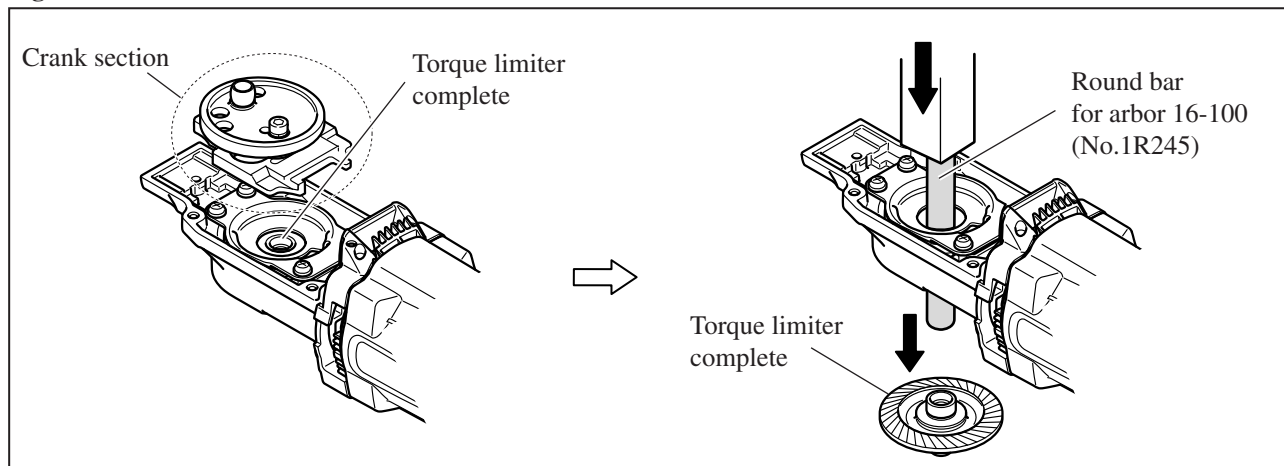
## ► Repair

### [3] -4. Replacing Torque Limiter Complete

#### DISASSEMBLING

- 4) After separating crank section from torque limiter complete, remove torque limiter complete from gear housing by pressing down with arbor press and Round bar for arbor 16-100 (No.1R245). (**Fig. 25**)

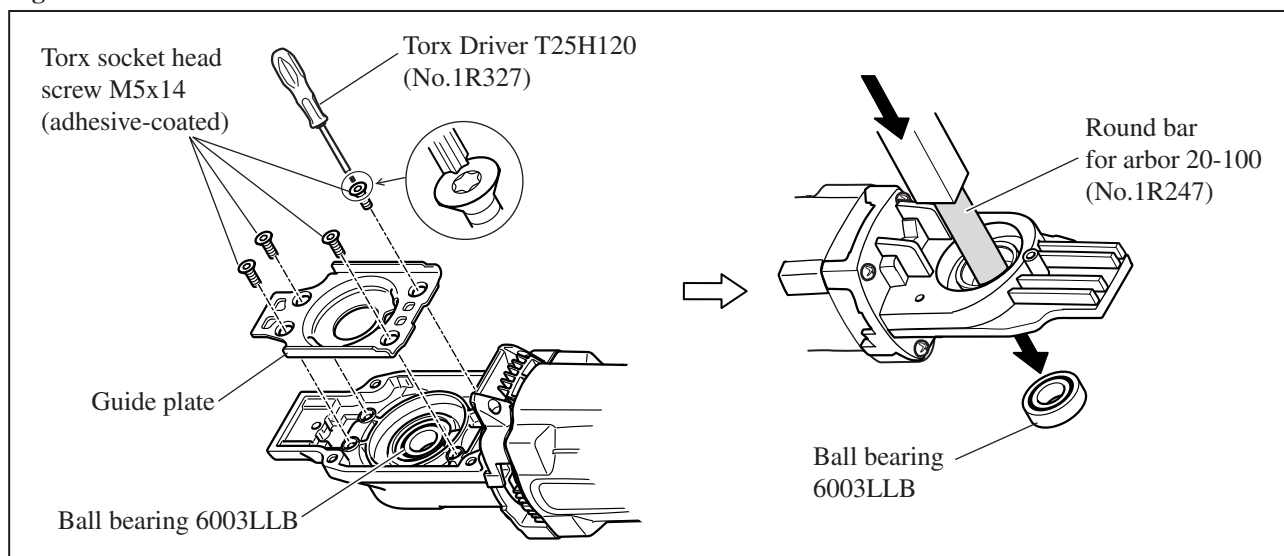
**Fig. 25**



- 5) Unscrew four M5x14 torx socket head screws (adhesive-coated) using Torx Driver T25H120 (No.1R327), and then remove guide plate from gear housing.

Turn over the tool, and now ball bearing 6003LLB can be removed from gear housing by pressing down with arbor press and Round bar for arbor 20-100 (No.1R247). (**Fig. 26**)

**Fig. 26**



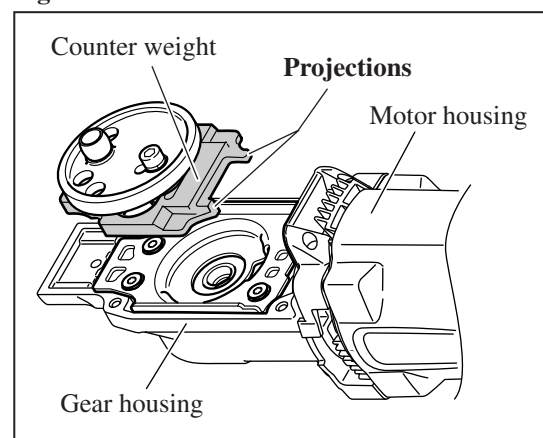
#### ASSEMBLING

Do the reverse of the disassembling steps.

#### Note:

- 1) Tighten torx socket head screw M5x14 with Torque wrench shaft 2-6N.m (No.1R254) to the recommended torque of 2.9-5.9N.m (30-60 kgf.cm).
- 2) Counterweight is not reversible when assembled to gear housing. As illustrated in **Fig. 27**, be sure to place it so that the two protrusions faces towards the direction of motor housing.
- 3) When fastening torque limiter complete, tighten with Torque wrench shaft 20-90N.m (No.1R223) to the recommended torque of 29.4-39.2N.m (300-400 kgf.cm).

**Fig. 27**



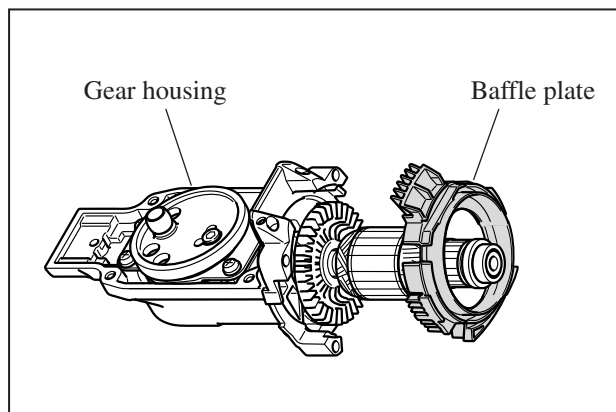
## ► Repair

### [3] -5. Replacing Armature

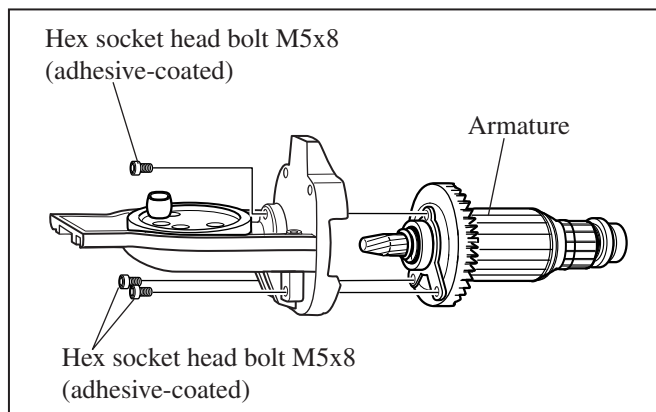
#### DISASSEMBLING

- 1) After removing insulation cover and shoe, separate gear housing cover complete from gear housing. (**Fig. 15**)  
It is not necessary to remove lever 20 and pin 7.
- 2) Remove carbon brush. Separate motor housing from gear housing by removing four 5x35 tapping screws that fasten gear housing to motor housing.
- 3) Remove baffle plate. (**Fig. 28**)
- 4) By removing three M5x8 hex socket head bolts, armature can be separated from gear housing. (**Fig. 29**)

**Fig. 28**

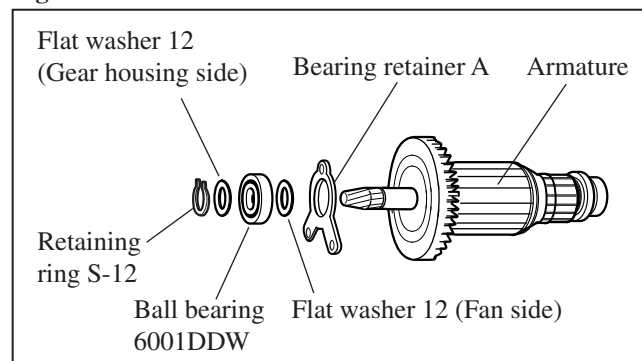


**Fig. 29**



- 5) Remove retaining ring S-12 with Retaining Ring S and R Pliers (No.1R291).  
Now the flat washer 12 on the gear housing side can be removed. (**Fig. 30**)
- 6) By removing ball bearing 6001DDW with Bearing Extractor, small (No.1R269), the flat washer 12 on the fan side and bearing retainer A can be removed from armature. (**Fig. 30**)

**Fig. 30**



#### ASSEMBLING

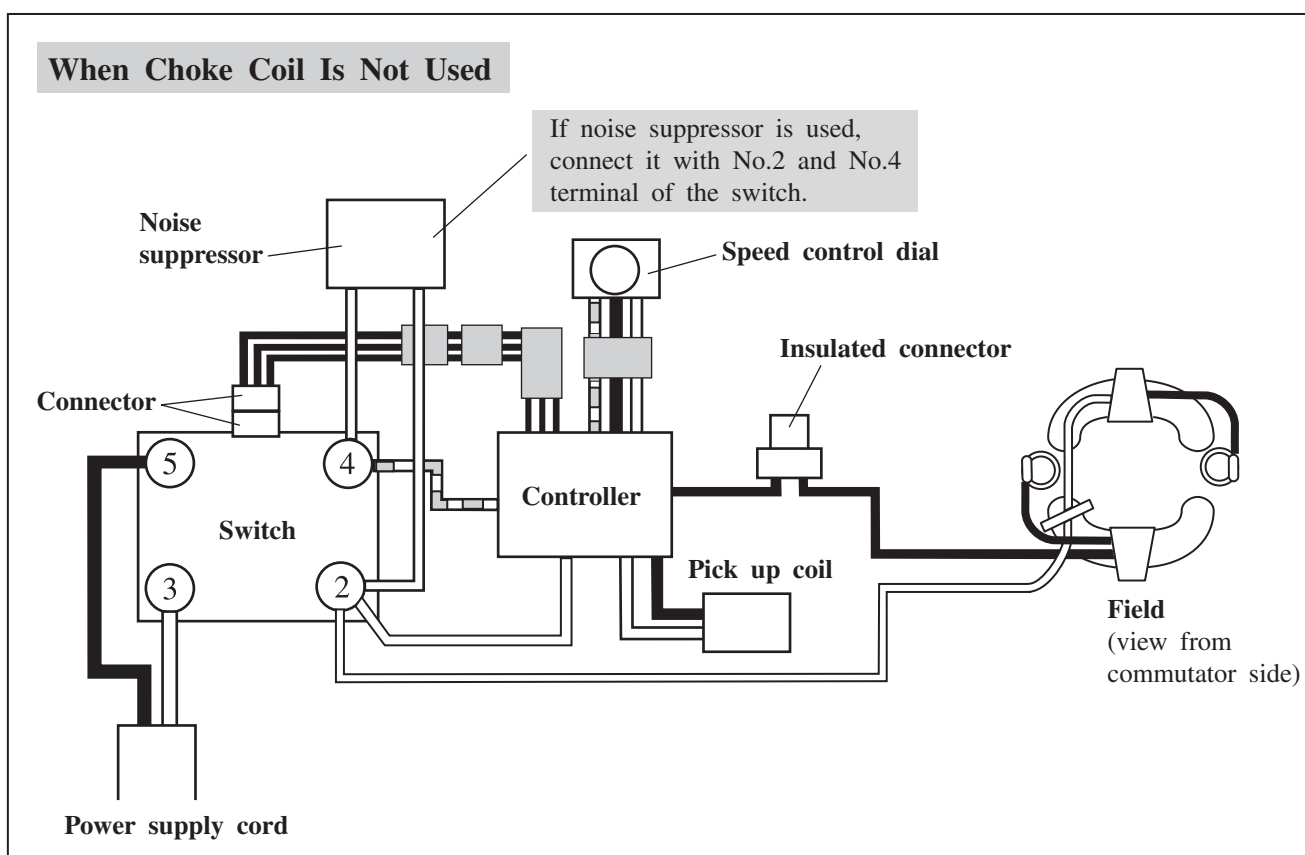
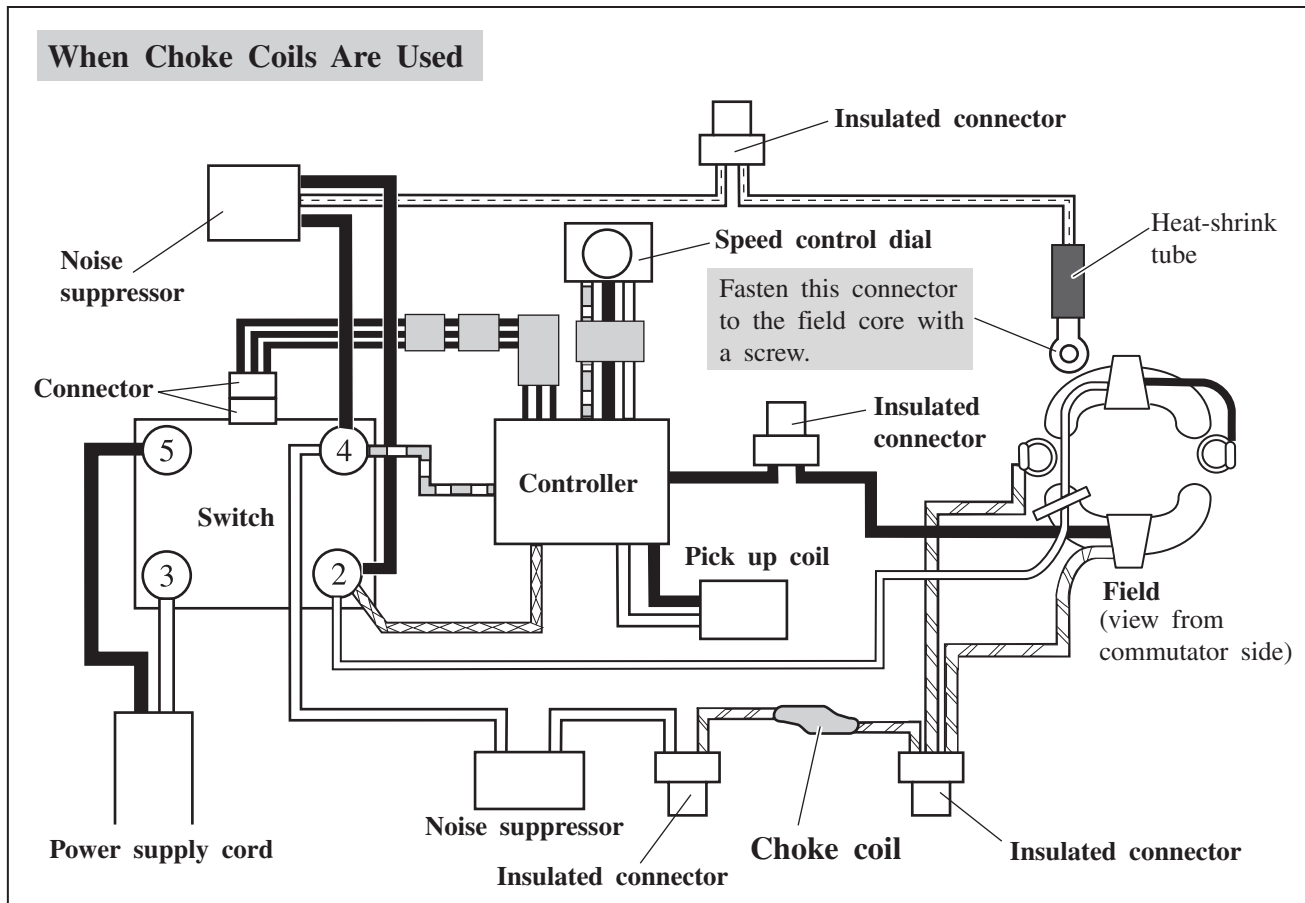
Do the reverse of the disassembling steps.

#### **Note:**

Do not forget to put flat washer 12 (2 pcs) in place. (**Fig. 30**)

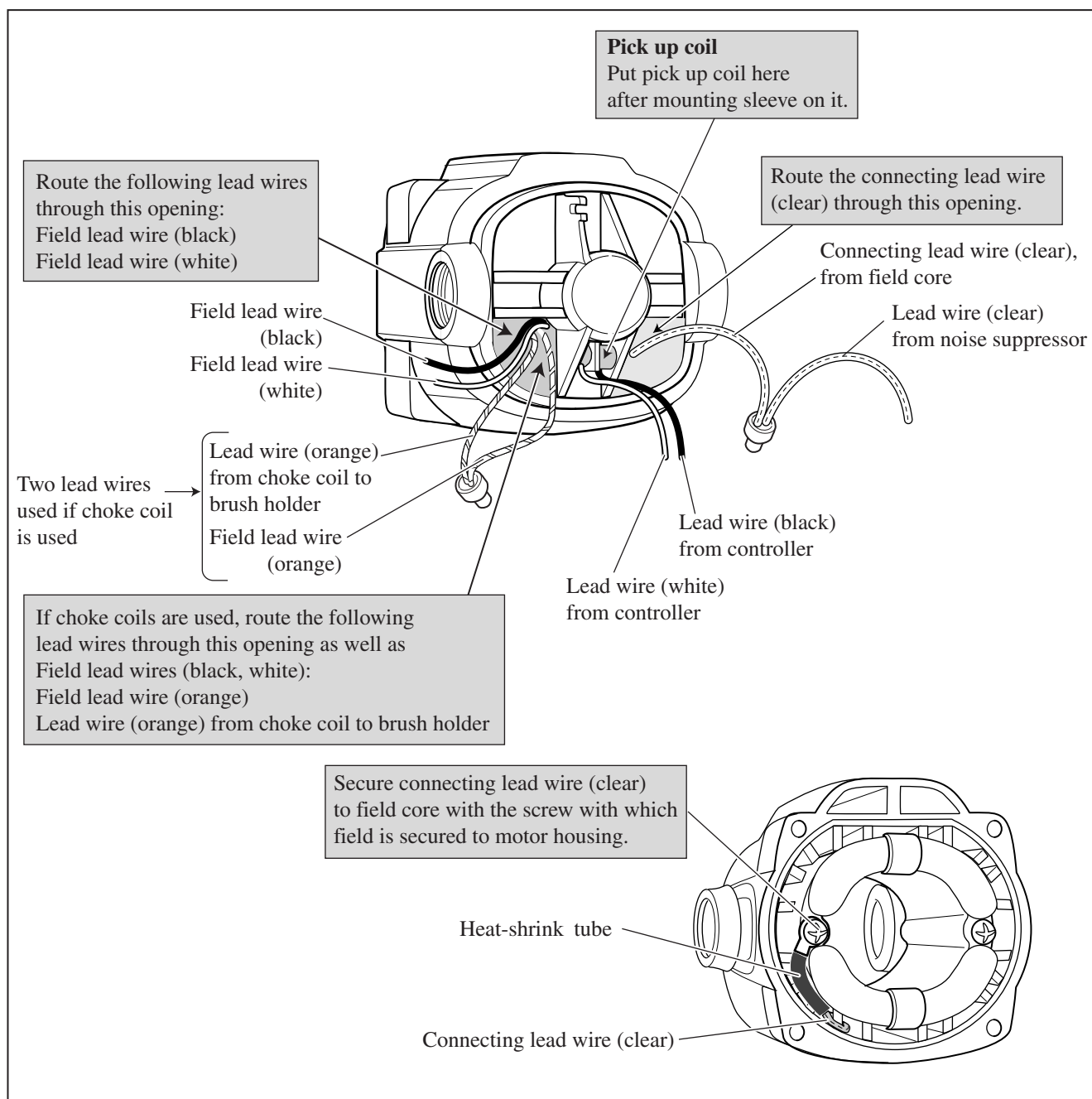
► **Circuit diagram**

Color index of lead wires' sheath			
Black		Orange	
White		Blue	
Red		Clear	



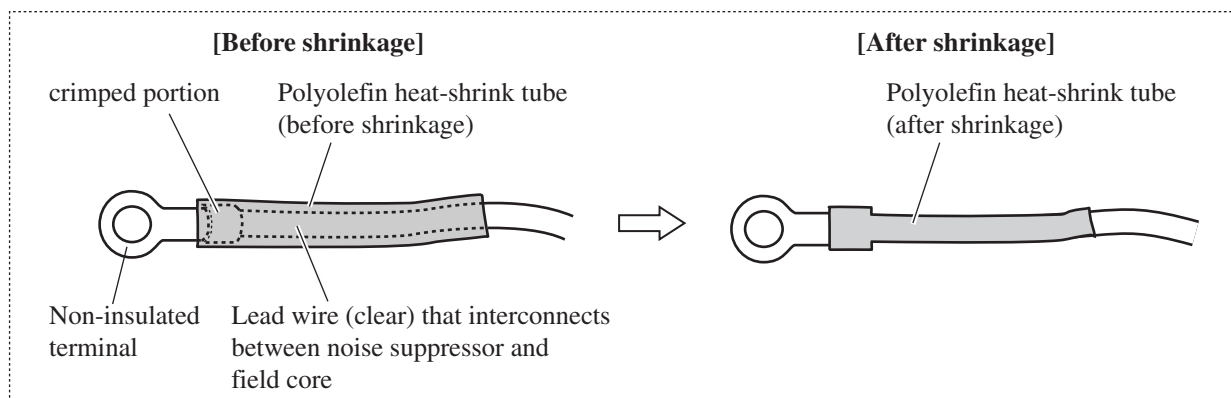
► **Wiring diagram**

**[1] Wiring in Motor Housing**



**[Protecting the Interconnecting Lead Wire with Heat-Shrink Tube]**

In case that noise suppressor is used, protect the lead wire that interconnects between noise suppressor and field core using polyolefin heat-shrink tube. Be sure to cover the crimped portion as illustrated below.



► **Wiring diagram**

[2] **Wiring in Handle**

